

Intelligent Rotary Oven



Diesel Oil Heat & LPG/LNG Gas Heat Type

Operation Manual

**TO GET THE BEST PERFORMANCE OF YOUR MACHINE, READ THIS MANUAL
CAREFULLY**

CONTENTS

Contents	Page 1
Introduction	Page 2
Attention	Page 2
Installation Warnings	Page 3
Installation and Service	Page 3.4
The Equipment Introduction	Page 5
Technical Parameters	Page 6
Installation	Page 7.8
Operating	Page 9.10
Basic Functions	Page 11
Basic Operations	Page 12.13
The Equipment Maintenance	Page 14.15.16
The Equipment Troubleshooting Guide	Page 17
The Burner Troubleshooting Guide	Page 18
The Equipment Structures	Page 19.20.21.22.23.24
The Electrical Diagrams	Page 25.26

**IMPORTANT SAFETY INSTRUCTIONS
READ AND RETAIN THESE INSTRUCTIONS**

**DANGER
TO REDUCE THE RISK OF FIRE OR ELECTRIC SHOCK,
CAREFULLY FOLLOW THESE INSTRUCTIONS**

INTRODUCTION

The manufacturer suggest reading this manual carefully before use.

This equipment is built with high quality materials by experienced technicians. Proper installation and maintenance will ensure reliable performance for years to come.

A nameplate located on the right or left side of oven provides essential details, including the model number, serial number, voltage, and amperage.

Drawings, replacement parts numbers and electrical diagram are included in this manual.

ATTENTION

The manufacturer is not responsible for any property or equipment damage caused by personnel who are not certified by recognized organizations. The customer is responsible for hiring qualified technicians for the oven's electrical and plumbing installation.

SHIPPING

For your safety, this equipment has been inspected by qualified technicians and securely crated before shipment. Upon accepting the transports, the shipping company assumes full responsibility for delivering the equipment in good condition.

REQUIRED CLEARANCE FOR INSTALLATION NEAR FLAMMABLE PRODUCTS

A) Back of the oven:

Maintain a minimum clearance of 50 cm.

B) Top of the oven:

Ensure a clearance of at least 90cm from the ceiling to allow proper venting of the exhaust pipe and hot components, as well as to provide adequate access for maintenance.

C) Floor:

The oven must be installed on a non-combustible floor.

D) Sides of the oven:

Maintain at least 1.5 meters of clearance on both the left and right sides to ensure easy removal of components during maintenance.

INSTALLATION WARNINGS

POWER FAILURE WARNING

IN THE EVENT OF A POWER FAILURE, TURN OFF THE OVEN'S POWER SWITCH TO PROTECT THE ELECTRONIC COMPONENTS WHEN POWER IS RESTORED.









FOR YOU SAFETY





DO NOT STORE OR USE GASOLINE OR OTHER FLAMMABLE VAPORS AND LIQUIDS NEAR THIS OR ANY OTHER APPLIANCE.

INSTALLATION AND SERVICE

WARNING

**IMPROPER INSTALLATION, ADJUSTMENT, ALTERATION, SERVICE, OR MAINTENANCE CAN RESULT IN PROPERTY DAMAGE, INJURY, OR DEATH.
CAREFULLY READ AND UNDERSTAND THE INSTALLATION, OPERATING, AND MAINTENANCE INSTRUCTIONS BEFORE INSTALLING OR SERVICING THIS EQUIPMENT**

-  **The electrical supply installation must comply with the electrical ratings indicated on the nameplate.**
-  **The equipment must be connected to an earth line and equipped with an electrical leakage switch.**
-  **Use oil-resistant and toughness wiring. Replace any aging wiring, ensuring the length is no less than 3 meters.**
-  **We highly recommend using a water filter to eliminate minerals in the water (for the steam system).**
-  **This equipment is intended for professional bakers only.**
-  **Before performing any repair or maintenance, ensure the power supply is turned off.**
-  **Only qualified technicians should repair and maintain this equipment**
-  **This equipment is designed exclusively for baking food items and should not be used for other purposes.**
-  **For safety, check the electrical components before turning on the power.**

-  **When the power is on, the user must monitor the equipment closely.**
-  **This equipment must be installed with proper ventilation in accordance with local building codes.**
-  **During transportation, always use a forklift truck for loading and unloading.**
-  **It is forbidden to unload the trolley while the oven is in operation.**

The manufacturer reserves the right to modify the structure, performance, appearance, and other aspects of this equipment.

I THE EQUIPMENT INTRODUCTION

This equipment is ideal for baking a variety of items, including bread, rolls, toast, hamburgers, cookies, pies, cakes, biscuits, croissants, buns, meats, dry foods, and more.

Baking Features

- Platform trolley for uniform baking and easy loading and unloading.
- High production capacity.

Mechanism Features

- Two vertical rows of adjustable stainless steel louvers to meet the baking requirements of different products.
- Ventilation hood with a powerful blower fan for efficient heat removal.
- Automatic stop trolley platform for easy loading and unloading.
- Elegant and sleek appearance with low noise, low energy consumption, and labor-saving design.
- Insulation with excellent heat retention (thickness: 13.5cm)
- High quality stainless steel construction, resistant to deformation.

Electrical Features

- Fast and slow hot air circulation to ensure the baking requirements of different products are met.
- Door switch controls the platform, ensuring accurate stop positions for easy loading and unloading.
- Precise timer for easy control of baking time.
- Smart overheat protection thermostat with minimal temperature variation.
- Malfunction indicators for heating, rotation, ventilation hood blower fan, fast and slow hot air circulation, simplifying repair and maintenance.

II. TECHNICAL PARAMETERS

- Capacity: 32 trays
- Tray Size: 400*600 mm (Max.460*720 mm) or customized 800x1000 mm
- Voltage: 220V/380V~3N
- Hertz: 50Hz / 60Hz
- External Dimensions: 2770*1910*2755 mm
- Net Weight: \approx 1900KG
- Rotary Oven Model Code:

MSRT— 64 D/E/G

Capacity

Heat method

D—Diesel

E—Electrical

G—LPG / LNG Gas

Specification Explanations

- When purchasing this equipment, please provide the tray size and product baking requirements to help the manufacturer offer the correct trolley size and baking cavity design.
- Standard Voltage: 380V 3N~ 50Hz (Acceptable: 220V 3N~ 60Hz)
- Standard Baking Tray Size: 400*600 mm (Max. 460*720 mm)
- Special voltage and baking tray size are available. Please confirm with the manufacturer before placing an order.

Model List

Model	MSRT-32E	MSRT-32D	MSRT-32G
Capacity	32 trays	32 trays	32 trays
(V)	220/380V 3N AC 240/415V 3N AC	220/380V 3N AC 240/415V 3N AC	220/380V 3N AC 240/415V 3N AC
(A)	78	5.25	5.25
(KW)	54	3.5	3.5
External(mm)	2770×1660×2755	2770×1910×2755	2770×1910×2755
N.G (kg)	1800	1900	1900
Model	MSRT-64E	MSRT-64D	MSRT-64G
Capacity	64 trays	64 trays	64 trays
(V)	220~3N/380V~3N/ 415V~3N AC	220~3N/380V~3N/ 415V~3N AC	220~3N/380V~3N/ 415V~3N AC
(A)	104	7.5	7.5
(KW)	72	5	5
External(mm)	2390x3150x2755	2390x3150x2755	2390x3150x2755
N.G (kg)	2850	2850	2850

III. INSTALLATION

- When this equipment is shipped disassembled, it will be divided into three parts: the front door, central cavity, and heat exchanger. Before delivery, remove all packaging. The front door part is heavier and more fragile than the other parts, so handle with care during shipment to prevent deformation or breakage.
- When shipped assembled, the equipment should be moved on a flat surface using a forklift. The forklift's fork length must be no less than 1.6 meters. When lifting from left or right side, ensure the machine body remains balanced and lift slowly.
- The front door part components are heavy and fragile, so take extra care during transportation.
- When transporting, place a pallet under the forklift forks to ensure safe handling.

Shipment Instruction Figures

(a) Lift-up Direction: from the back side

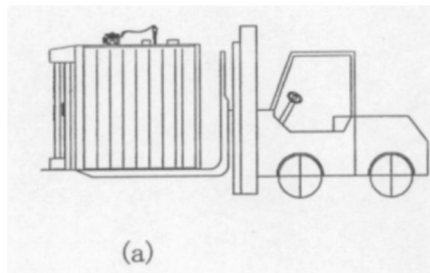

(b) Lift-up Direction: from the right or left side

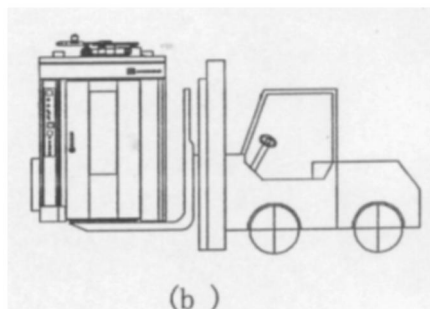

Attention : During the transportation, prevent exposure to rain and avoid collision

● This equipment should be installed in a properly ventilated and well-lit environment. Ensure to pre-configure an exhaust opening.

- According to the provided diagram, remove the blower fan from the carton, install it into the ventilation hood elbow pipe, and connect the fan switch to the oven.

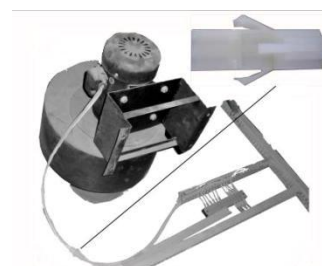

- For the electrician: Ensure that the supply cable does not come into contact with the oven top, which becomes hot. A phase sequence and phase loss relay are installed on the 3-phases model conductors in the electrical control box. Make sure the power is properly connected to the 3-phase wires.
- Connect the water supply pipe to the oven using high quality sealing compound.

Ensure that combustible water pipes do not come in contact with the hot parts on top of the oven.
Check for any leaks in the solenoid valve.

Notes: The water flow valve for the steam system has been fixed. DO NOT TOUCH.

Connect the steam system to the cold water distribution network.

- After installation, check all connected parts and conduct an initial test of the oven. Observe and confirm that the oven is in proper working condition before preceding with the baking test.
- When performing the baking test, load the test products into the oven and set the temperature and baking time accordingly.
- The external cable must be of the YZW oil-resistance type (#245 lines in IEC57). The user must install a leakage switch to connect the oven, with each pole contact requiring a minimum gap of 3mm.
- Cable specifications required: $3 \times 16 + 2 \times 6 \text{ mm}^2$ (for internal electrical connections only).

IV. OPERATING

The Main Control Panel

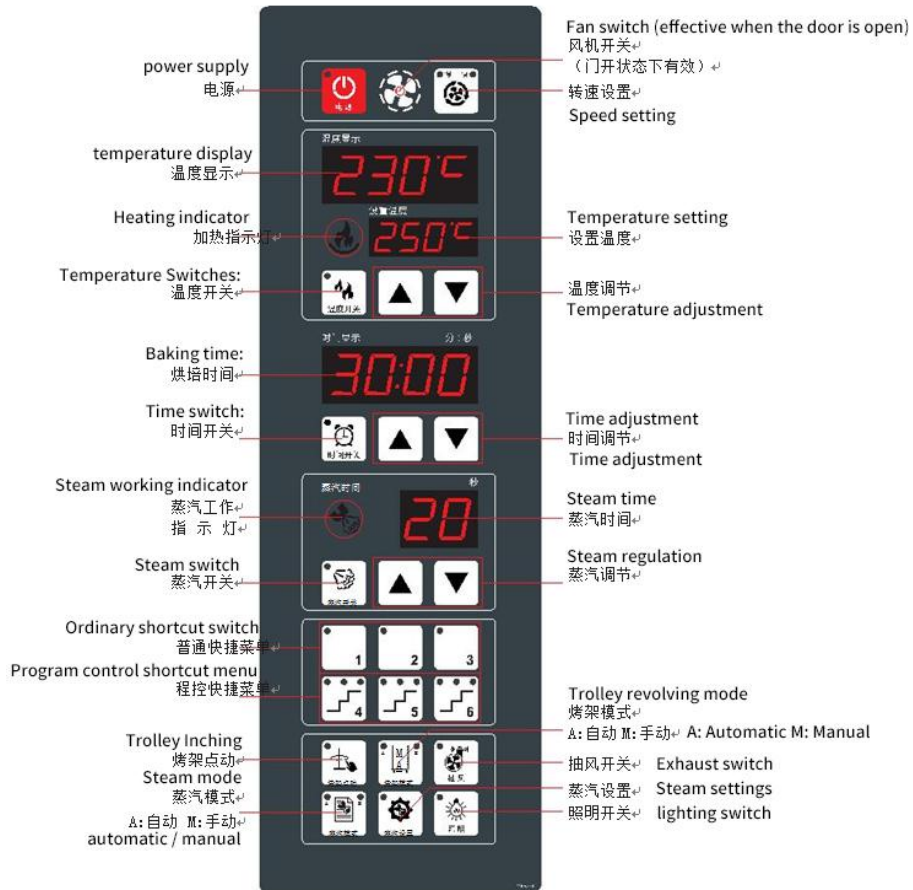

The Malfunction Indicators' Panel (Installed on the control box on oven's roof)



V. BASIC FUNCTIONS

Temperature Function

- Turn the knob to set the desired temperature.

Timer Function

- Turn the knob to “ON” and press the “▲▼” buttons to choose the desired time setting.

Steam Generation Function

- Steam output can be activated only when the oven’s temperature is $\geq 200\text{ }^{\circ}\text{C}$ (steam threshold).
- Connect the water pipe to the oven’s water intake and ensure water is flowing before turning on the steam system.
- Turn on the steam switch, and the steam system will automatically spray steam in 3-second intervals after 3 minutes, in a continuous circle.
- The steam spray time is set to 3 seconds (adjustable from 0 to 6 seconds).
- The steam cycle time begins once activated, with a frequency of 3 minutes (adjustable from 0 to 3 minutes).
- If the steam cycle is not needed, press the steam knob to turn off the steam function.

Notice!!! The above times have been pre-set by the manufacturer. Any adjustments to these settings must be made by a qualified technician.

Light Function

- Press “LIGHT” to turn the lamp on.

Slow and Fast Speed Hot Air Circulation Function

- Select either “SLOW” or “FAST” speed hot air circulation based on the product’s baking requirements.

Manual Mode and Auto Operation Switch Function

- Manual Mode: When the door is opened, the trolley will keep rotating.
- Auto Mode: When the door is opened, the trolley will stop in the correct position, and the hood blower fan will automatically start.

Attached (Baking methods)

Product	Weight	Temperature	Time
---------	--------	-------------	------

Common bread	60g/pc	180℃—190℃	10 minutes
Toast	1000 g/pc	180℃—185℃	40 minutes
Baguette	300 g/pc	225℃—230℃	30 minutes
Moon cake	125 g/pc	190℃—200℃	15 minutes
Pastries	50 g/pc	190℃—200℃	10 minutes

VI. BASIC OPERATIONS

Operating Steps

The First Step

- Turn on the oven.
- Ensure the equipment is properly connected to the power supply. When the power switch is turned on, the power indicator will light up.

The Second Step

- Preheat the oven.
- Turn the knob to set the desired temperature.
- Press “ON” on the timer, and the “ON” indicator will light up. Set the desired baking time using the “▲▼” buttons.
- After setting, the oven will start heating up. Once the probe temperature reaches the set point, maintain this temperature for 10-15 minutes to equalize the oven’s internal temperature.

The Third Step

- Begin baking.
- Open the oven door, load the trolley into the oven cavity, and close the oven door. Set the temperature and baking time and begin baking.

The Fourth Step

Temperature Adjustment Methods:

- To get more upper heat, ensure the probe temperature reaches the set point before loading the trolley into the cavity.
- For more bottom heat, use a longer baking time with a lower temperature.
- If the probe temperature is too high when loading the trolley, it may cause insufficient bottom heat. In this case, reduce the baking temperature and extend the baking time.
- For better monitoring, you can observe the baking process through the glass door to ensure proper baking.

The Last Step

- Unload the trolley out of the oven.

- When the baking time reaches the set point, the buzzer will sound. Unload the trolley, and close the oven door to retain enough temperature for the next baking cycle.

Useful Adjustments

- ① The new oven should be set to 30°C higher than normal temperature settings during initial use.
- ② The new baking tray should be set to 20°C higher than normal.
- ③ If uneven baking occurs, adjust the two vertical rows of stainless steel louvers based on the actual baking result inside the cavity and test again.

Notice!!! Only experienced technicians are allowed to adjust the louvers. Ensure the oven has completely cooled down before making any adjustments.

The Trolley Usages

- If the probe temperature has not yet reached the set point, loading the trolley into the oven may result in insufficient upper heat and excessive bottom heat.
- Improper loading of the trolley or baking tray can cause uneven baking.
- When loading the trolley into the oven cavity, ensure the trolley is pushed to the center of the platform.
- The trolley must be fully locked by the spring locker before starting the baking process.

The Hot Air Circulation Speed Selection Rules

- For products baked in molds, select slow speed and a longer baking time.
- For products that require a crispy texture and deep color, choose fast speed, high temperature, and a shorter baking time.
- For larger products, select slow speed and a longer baking time.
- For smaller products, choose fast speed and a shorter baking time.

VII. THE EQUIPMENT MAINTENANCE

The oven waterproofing grade: IPX1

DO NOT CLEAN THE APPEARANCE WITH WATER!!!

To ensure optimal performance and long-term service life of the rotary oven, please strictly follow the maintainance procedures outlined below:

Daily Cleaning

- After the oven has cooled down completely, use warm water or a kitchen cleaner with a soft cloth to clean the oven cavity, trolley, glass, and external surfaces .Do not use metal steel cleaners or any cleaners that contain acidic or bleach ingredients.
- If the oven is powered by diesel or gas, before turning on the oven, check the diesel or gas level to ensure there is enough to support daily use. Clean the diesel oil container with a soft cloth, and always remember to shut off the oil or gas valve before leaving work.

Monthly Cleaning

- Clean the water filter and check for any leakage (the manufacturer does not equip a water filter with the rotary oven, but we highly recommend that the user install one for the oven).
- Lubricate the trolley platform bearings and trolley casters. If any damage is found, replace the parts immediately.
- Check the tension of the drive belt or chain, make any necessary adjustments, and lubricate the chain (recommended: grease oil).
- Use grease oil to lubricate the door shaft and door handle, ensuring that both the door and handle are in proper working condition.
- Remove the oil or gas burner, clean any dust and debris around it, and especially clean the diesel oil filter. It must be removed and cleaned.
- Cheak the lubrication oil volume for the floor ramp that drives the trolley, and ensure it is at the correct level.
- After every 300/500 working hours, replace the lubrication oil in the reducers. After every 850/1500 working hours, replace the worm gear lubrication oil. Before starting the oven, ensure there is enough lubrication oil in both the the reducers and worm gears to maintain proper functioning of the driving system.
- Check the power supply cable to ensure it is properly connected to the oven. If any loose connections or dust on the wires are found, call a qualified electrician for repairs.
- Inspect the water flow valve and water supply pipe for the steam system to ensure they are in

proper working condition.

Quarterly Cleaning

- Use a soft brush or vacuum cleaner to clean all electrical parts, the machine body, circulation fan, and hood blower fan.
- Check and test the control system to ensure proper heating. Test the temperature controller, timer, and other functions, and verify that all meters are in proper working condition.
- Inspect the door seal. If any damage is found, replace it immediately to ensure the oven maintains good heat preservation.
- If the water pipe is blocked, remove it and clean it. If necessary, replace the pipe.
- Check the lamp. If necessary, replace it.
- For diesel oil burner, gas burners, or electrical heaters, perform a full inspection each quarter. Ensure the burner and heaters in proper working condition, and clean any dust from the burner openings.
- Clean the oil nozzle and ignitor pins of diesel oil burner, ensuring the oil filter is not blocked.

Yearly Cleaning

In addition to the routine maintenance tasks, it is recommended to establish an annual maintenance plan.

- For electric rotary ovens, a qualified electrician must inspect all electrical components. Test all heating elements, and if any damage is found, replace them immediately to ensure proper heating performance.
- For diesel oil or gas rotary ovens, a qualified electrician must also inspect all electrical components.
- Cleaning the heat exchanger is necessary. Cleaning Method:
 - ① Remove the burner.
 - ② Use high-pressure air to blow out dust and debris from the heat exchanger.
 - ③ Ensure that most of the dust is cleared away to maintain proper operation and extend the service life of the heat exchanger.

IMPORTANT NOTICE!!!



FOR GAS TYPE ROTARY OVEN ONLY

Gas Type	LNG Gas	LPG Gas
----------	---------	---------

Calorie	8500-9000Kcal/m ³	20000-22000Kcal/m ³
Consumption	9-22 m ³ /H	4-9 m ³ /H
Working Pressure	2-3.5Kpa	2.5-3.5Kpa
Flow Rate	35kg/H	35kg/H

P.S: The test oven model : MSRT-64G (2 trolleys, 64 trays, tray size 400*600mm)

⚠ Gas consumption rate will vary based on actual baking requirements. If the oven heats up too fast, turn down the gas valve to adjust the temperature. If the oven heats up too slowly, turn up the gas valve to increase the heat supply.

⚠ The mentioned working pressure applies to the normal combustion of the gas burner, not to the static pressure.

⚠ The gas burner's normal combustion depends on both the working pressure and the gas calorific value.

VIII. THE EQUIPMENT TROUBLESHOOTING GUIDE

Issue	Possible Causes	Solutions
The oven does not turn on.	A.) Incorrect phase connection	Reverse the two-phase feeders in the electrical control box.
	B.) Malfunctioning door switch	Repair or replace the door switch.
	C.) Blown fuse	Reset or replace the fuse.
	D.) Damaged power switch	Replace the power switch.
The trolley tripod platform is moving, but the fast and slow speed circulation motor does not react.	A.) Damaged fast and slow speed circulation switch	Replace it.
	B.) Faulty contactors or disengaged coil	Repair or replace it.
	C.) Tripped overload relay	Repair or replace it.
	D.) Damaged fast and slow speed circulation motor	Repair or replace it.
	E.) Abnormal power supply	Check and ensure proper power connection.
The hood blower fan is functioning, but the fast and slow circulation motor does not react.	A.) Oven door is not closed properly	Close the door securely.
	B.) Malfunctioning door switch	Repair or replace it.
The fast and slow speed circulation motor is functioning, but the trolley platform does not move.	A.) Damaged trolley driving motor	Repair or replace it.
	B.) Improper connection of trolley driving motor	Repair the connection.
	C.) Tripped overload relay	Repair or replace it.
When opening the door, the trolley stops at an incorrect position.	A.) Damaged door switch	Repair or replace it.
	B.) Disengaged door switch	Secure it properly.
	C.) Improper door switch connection	Repair it.
When opening the door or when the set time is reached, the hood blower fan does not react.	A.) Damaged hood blower fan motor	Repair or replace it.
	B.) Faulty contactors or disengaged coil	Repair or replace it.
	C.) Tripped overload relay	Repair or replace it.
	D.) Jammed hood blower fan	Remove the obstruction and repair it.
	E.) Faulty timer	Replace it.
When the set time is reached, the buzzer does not sound.	A.) Disengaged buzzer connection	Check and secure it.
	B.) Faulty timer or buzzer	Replace it.
Pressing the steam switch does not activate the steam system or produces no steam.	A.) Damaged steam switch	Replace it.
	B.) Blocked water flow valve	Clean and repair it.
	C.) Faulty steam time relay	Replace it.
	D.) Low water supply pressure	Adjust spray time and improve water supply conditions.
The steam system does not stop or excessive water enters the oven cavity.	A.) Overly long water spray duration	Adjust spray time to 2-3 seconds.
	B.) High water supply pressure	Reduce water valve pressure.
	C.) Jammed water flow valve	Clean and repair it.
The door does not close	A.) Worn-out door seal	Replace it.

properly.	B.) Loose door louvers	Secure them properly.
Uneven baking results.	A.) Improper hot air louver adjustment	Adjust based on baking results.
	B.) Trolley platform not level	Adjust platform shaft, bearings, or trolley position.

IX THE BURNER TROUBLESHOOTING GUIDE

Issue	Possible Causes	Solutions
Burner does not react when power is turned on	A.) Faulty or improperly connected temperature controller, preventing signal transmission to the burner.	Repair or replace the temperature controller.
	B.) Damaged burner controller.	Replace the burner controller.
	C.) Malfunctioning burner controller.	Reset it by pressing the green reset switch.
Burner operates but fails to ignite	A.) No diesel or gas, or a clogged pipe.	Refill fuel, repair the oil filter or gas regulator, and clean connection pipes.
	B.) Air trapped in the connection pipes.	Open the air exhaust valve to release air, then restart the oven.
	C.) Clogged oil nozzle.	Clean or replace the nozzle.
	D.) Jammed or damaged solenoid valve.	Remove and clean or replace it.
	E.) Incorrect positioning of the oil nozzle and ignitor pins.	Adjust and test again.
	F.) Ignitor pin ceramic cover is broken, causing an electrical leak.	Replace the ceramic cover.
	G.) Malfunctioning oil pump or improper power connection.	Clean the pump and check the power supply.
Burner ignites but shuts off immediately	A.) Burning sensor is dirty or damaged.	Clean or replace it.
	B.) Faulty burner controller.	Replace it.
Air blasting occurs (typically after multiple failed ignition attempts)	A.) Loose or damaged oil nozzle causing oil leakage.	Tighten or replace the nozzle.
	B.) Delayed ignition (≥15 seconds).	(1) Clean dirty ignitor pins.
		(2) Secure loose ignitor.
		(3) Replace broken ignitor pin ceramic cover.
		(4) Repair or replace faulty ignitor transformer.
	C.) Dirty flame sensor.	Clean it.
	D.) Blocked chimney.	Clean it.
	E.) Low-quality diesel or gas.	Switch to better fuel.
F.) Heat exchanger has excessive buildup.	Clean it with high-pressure air.	
G.) Malfunctioning solenoid valve causing oil or gas leakage.	Repair or replace it.	

X. THE EQUIPMENT STRUCTURES

Single oven ventilation system layout (user-provided)

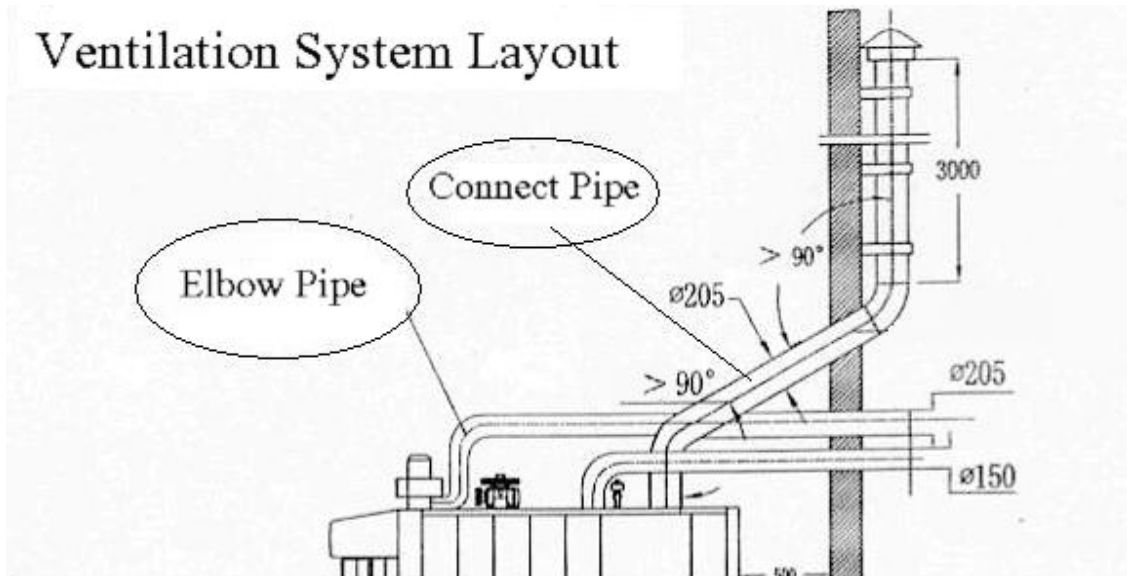

Multiple oven ventilation system layout (chimney connection section) (user-provided)

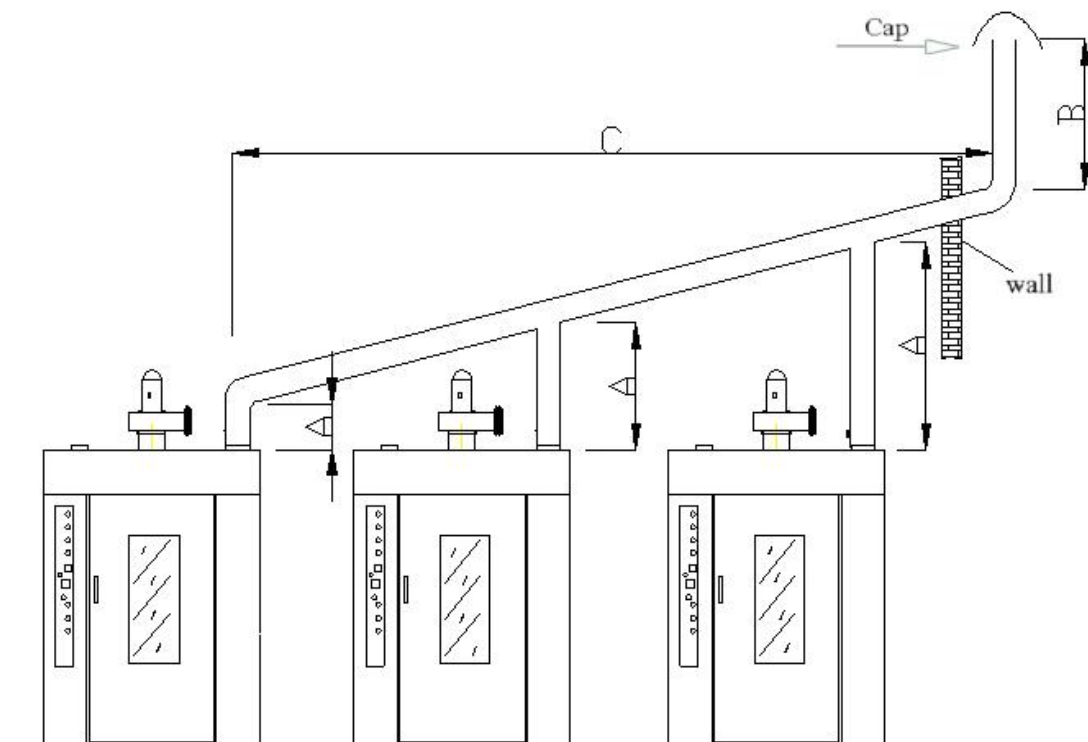

Requests:

1. Every corner should be connected with an elbow pipe.

2. The external chimney should be equipped with a cap to prevent rain and wind from flowing into the pipes.
3. The pipe diameter must be no less than 200mm.

Multiple oven exhaust system layout (user-provided) (connection of overheat exhaust pipe and hood blower fan)

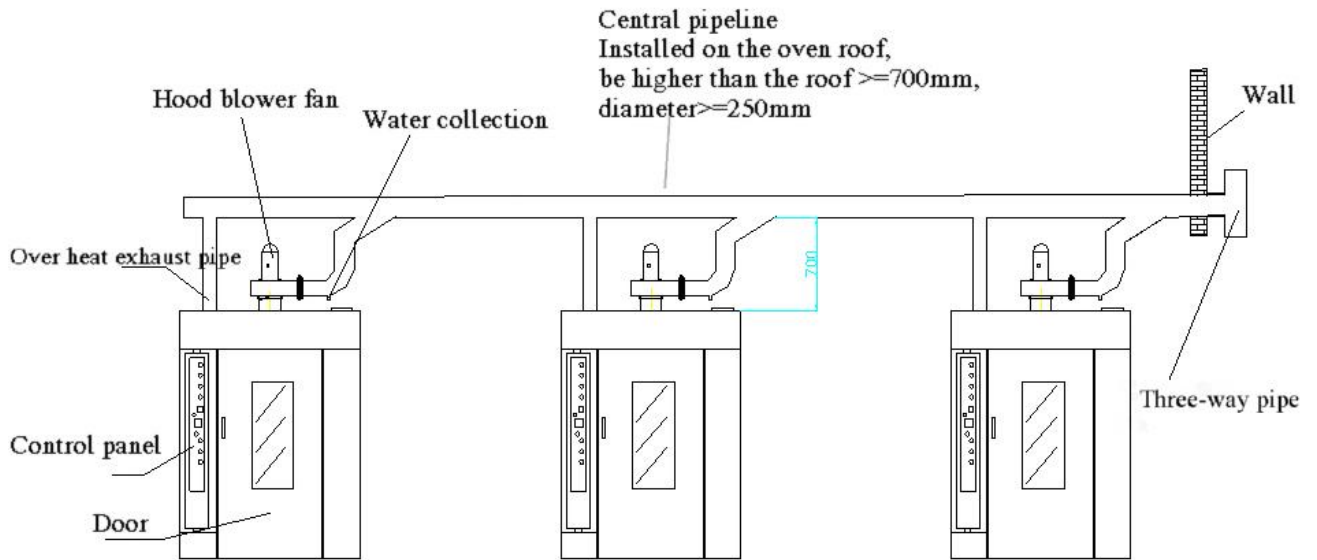

Diesel oil container layout for diesel oil-fueled rotary oven(user-provided)

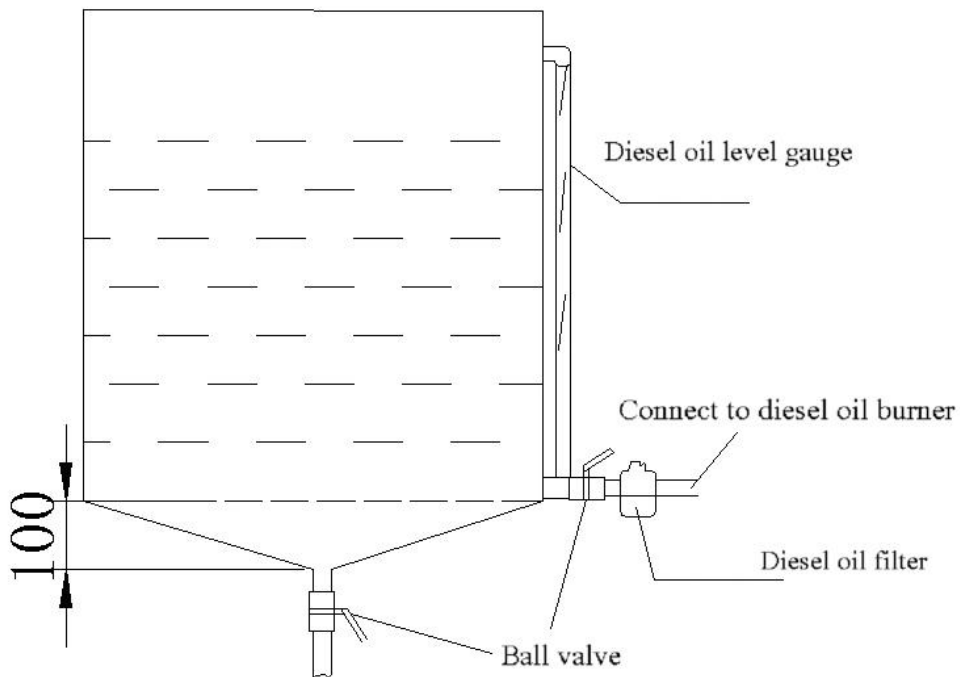

Requests:

- 1) Clean the diesel oil filter every six months.
- 2) Replace the filter element every six months.

- 3) After adding diesel oil, allow the rotary oven to run after 2 hours.
- 4) Clean the oil container every month. (Open the ball valve to drain water and waste.)

Burner Maintenance

Daily maintenance

- 1) Clean the burner's exterior environment.
- 2) Check the oil volume and quality.
- 3) Inspect the burner of any unusual noise during combustion.
- 4) Check the burner connections for loose parts.
- 5) Verify the power supply to ensure proper operation.
- 6) Check the volume meter and control system to ensure they are functioning correctly.

Quarterly maintenance

- 1) Clean the blower fan and combustor.
- 2) Clean the oil container to prevent accumulation of waste and water at the bottom.
- 3) Clean the oil filter and nozzle.
- 4) Clean the flame ignitor pins and flame stabilizer.

The Fast and Slow Hot Air Circulation Speed Motor Assembly

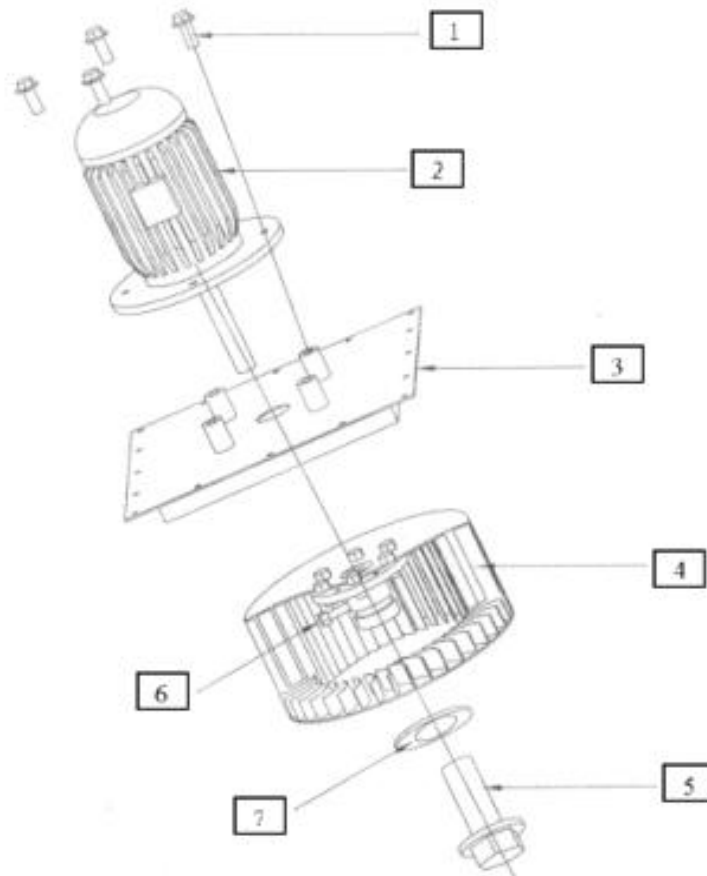

The Fast and Slow Speed Hot Air Circulation Motor Component Parts

No.	Name
1	Screw
2	Motor
3	Base
4	Fan
5	Screw
6	Screw
7	Spacer

The Fast and Slow Speed Hot Air Circulation Motor Installation

- ✓ First, place the motor upside down on the ground and install the base (3) onto the motor (2).
- ✓ Second, secure the motor and base together by tightening screw (1).
- ✓ Third, lubricate the motor shaft with grease oil.
- ✓ Fourth, install the fan (4) onto the shaft, insert the copper lock pin into the sleeve, and gently tap it with a plastic hammer.
- ✓ Finally, tighten screw (7) and (5) along with the flat spacer, then secure screw (6).

The Transmission System Assembly

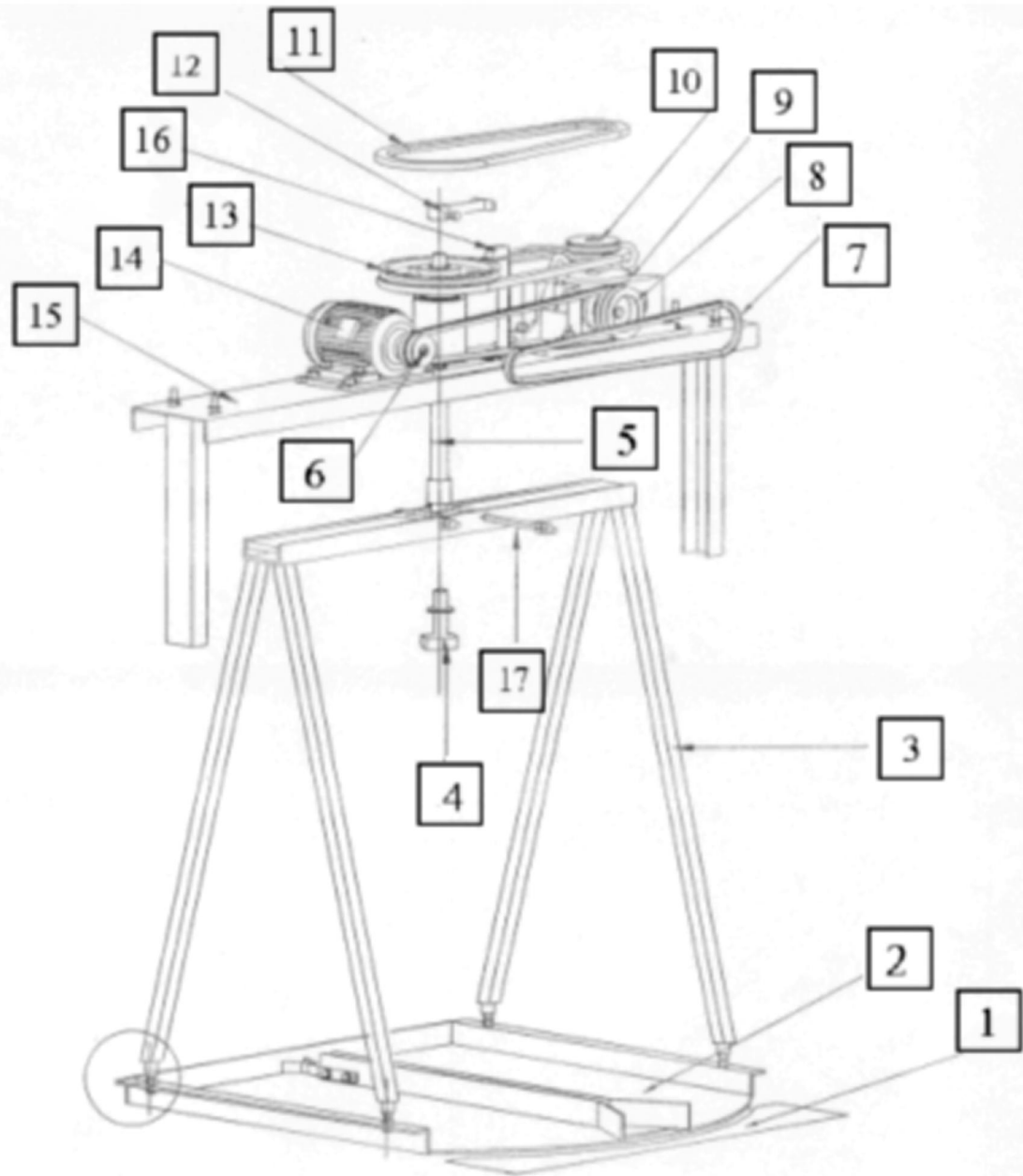

The Transmission System Components Part List

O.	N	NAME	NO.	NAME
	1.	Bottom plate	10.	Belt pulley
	2.	Turntable	11.	Belt
	3.	Trolley tripod platform	12.	Door switch induction block
	4.	Screw	13.	Belt pulley

5.	Drive shaft	14.	Motor (0.37kw)
6.	Belt pulley	15.	Base
7.	Belt	16.	Approach switch (door switch)
8.	Belt pulley	17.	Screw
9.	Reducer (60:1)		

The Transmission System Installation

1. Base Insulation

- Fill the opposite side of the base (15) with insulation material.
- Cut a "+" in the center of the insulation to allow the drive shaft (5) to pass through.

2. Install the Drive Shaft

- Insert the drive shaft (5) through the center hole of the base.
- Secure the drive shaft with an M8 bolt and spacer.

3. Fix the Reducer and Pulley

- Attach the reducer (9) to the right side of the base.
- Connect the belt pulley (13) and pulley (10) using the belt (11).

4. Install the Motor

- Mount the motor (14) on the base (15).
- Connect the motor's belt pulley (6) to pulley (8) using the belt (7).

5. Install the Trolley Tripod Platform

- First, tighten all bottom bolts of the trolley tripod platform (3).
- Place the turntable (2) into the oven cavity, then lift and connect the trolley tripod platform (3) to the drive shaft (5).
- Secure the platform with tightening screws (4) and (17), along with spacers.
- Tighten the turntable (2) at its four corners using M12 bolts.

6. Adjust Turntable Height

- The height of the turntable (2) must be 2mm higher than the bottom plate (1).

7. Turntable Running Direction and Auto Mode

- The turntable (2) should rotate clockwise when running.
- In auto mode operation, when the oven door is opened, the turntable (2) will stop and face the bottom plate (1) automatically.

8. Adjust the Stopping Position

- If the turntable (2) does not stop in the specified position, adjust the door switch induction block (12) and the approach switch (16) to ensure a proper stopping position.

